

TAS 1000 DISPLAY  
(P/N 1000-001)  
(DSUB-25 SOCKET)

(DSUB-25 PLUG)

2 AMP TRIP-FREE  
RESETABLE CIRCUIT BREAKER

10 TO 30 VDC 13  
AVIONICS GROUND 25

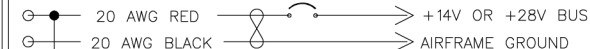

FF1A 21  
FF1B 8  
FF2A 6  
FF2B 7  
FF RETURN 20

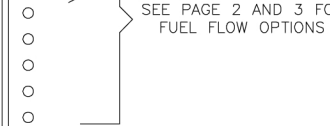

ALTITUDE  
ALERTER 5

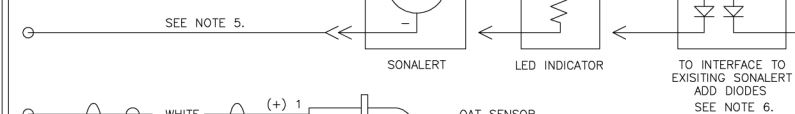

OAT HI 16  
OAT LO 4

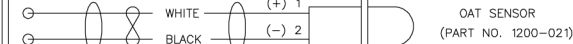

WINDICATOR HI 15  
SIGNAL GROUND 14

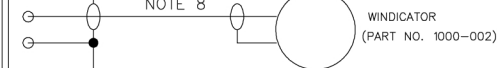

SA 12  
SC 24



SYNCHRO REF 9

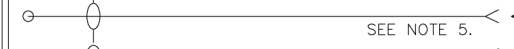

SYNCHRO X 19  
SYNCHRO Y 18  
SYNCHRO Z 17

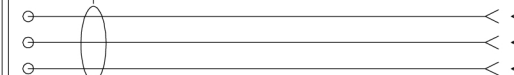

ENCODER HI 2



BAT DVM 22



RS232 RXD 23  
RS232 TXD 10  
SIGNAL GROUND 11

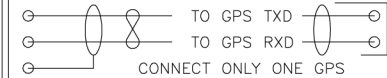

GARMIN 400 SERIES GPS (P4001) 56 RS232 OUT (P4001) 57 RS232 IN	BENDIX/KING KLN 89/89B/94 (P891) 2 RS232 OUT (P891) 1 RS232 IN	BENDIX/KING KLN 90B (J901) 13 RS232 OUT (J901) 36 RS232 IN	UPS APOLLO GX50/55/60/65 37 PIN CONNECTOR PIN 5 RS232 OUT PIN 4 RS232 IN	OTHER GPS SYSTEMS CALL INSIGHT
--	--	--	---	-----------------------------------

- NOTES:
1. ALL GPS AND TAS 1000 REQUIRE SOFTWARE COMMUNICATION CONFIGURATION.
  2. FOR SINGLE BATTERY AIRCRAFT NO CONNECTION TO PIN, 22 MOD C ONLY.
  3. ALL WIRING 24 AWG UNLESS OTHERWISE SPECIFIED.
  4. INSTALL JUMPERS INSIDE DSUB-25 PLUG CONNECTOR SHELL.
  5. OPEN DRAIN OUTPUT (EQUIV. SWITCH TO GROUND), DO NOT EXCEED 30VDC,0.5A.
  6. TO INTERFACE TO EXISTING SONALERT ADD DIODES, SONALERT MUST BE SWITCHED TO COMMON GND.
  7. WIRING FOR TAS1000 MOD "D"
  8. INSIGHT SUPPLIED WINDICATOR CABLE.

REVISIONS				
REV	PAGE	DESCRIPTION	DATE	APPROVED
A	1,3	CHANGED ENCODER LO FROM PIN 3 TO PIN 14. (1000-001)	JAN 3/00	JWT
	1	ADDED BARO SET LO INPUT PIN 3. (1000-001)		
	3	CHANGED STROBE TO OVERSPEED WARNING PIN 6. (1000-003)		
B	3	Changed Encoder Module from socket to plug.	FEB 1/00	JWT
	2	Added pin numbers to fuel flow sensor connectors.		
C	1	Revised notes and pin names, see ECN #TAS002.	JUNE 22/00	JWT
D	2	Revised Fuel Flow wiring, see ECN #TAS003.	Oct 1/00	JWT
E	1	ADDED ALTITUDE ALERTER	JUNE 15/2001	R.R.
F		ADDED DC FUEL FLOW.	3 SEPT 2002	R.R.
G		ADDED MODIFICATION FOR EXPANSION MODULE.	8 APR 2003	R.R.
H		ADDED FUEL FLOW GROUNDING NOTE.	15/MAR/05	R.R.
J		MODIFIED BARO REFERENCE.	10/AUG/05	R.R.

- TO PREVIOUS EXISTING CONNECTION.
- COMPASS OPTION NOTES:
1. MAKE CONNECTIONS AS IN OPTION A, B, C OR D.
  2. SYNCHRO X,Y,Z MUST BE SYNCHRONOUS WITH 400 HZ 26VAC.
  3. ● MAKE CONNECTIONS TO EXISTING A/C EQUIPMENT.
  4. OPTION B IS PREFERRED.

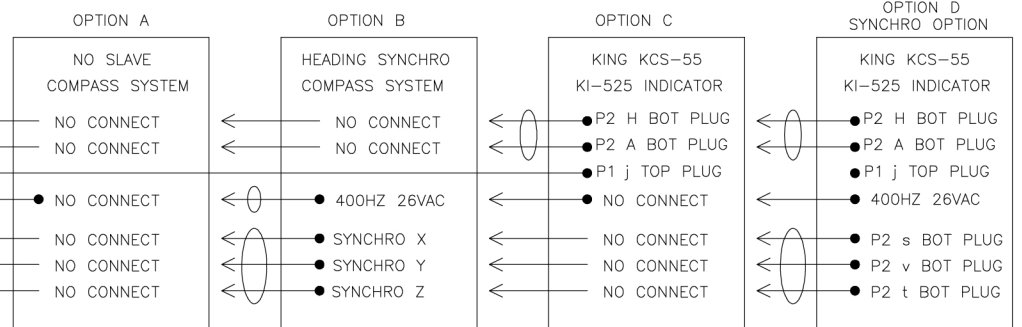

COMPASS OPTIONS

Insight

TAS 1000 INSTALLATION SCHEMATIC

Insight Instrument Corporation  
Box 122, Fort Erie, Ontario L2A 5M6

This drawing is the property of Insight Instrument Corporation and contains confidential and proprietary information. Reproduction or unauthorized use is strictly forbidden. © Copyright 1999		SIZE	FILE NAME:	DRAWING NO.	DRN	CKD	ICD	REV
		none	tasintj	1000-301	JWT	JWT	JWT	J
SCALE	DATE	SHEET		1 of 4				
	SEPT 1/99							

TAS 1000 DISPLAY  
(P/N 1000-001)  
(DSUB-25 SOCKET)

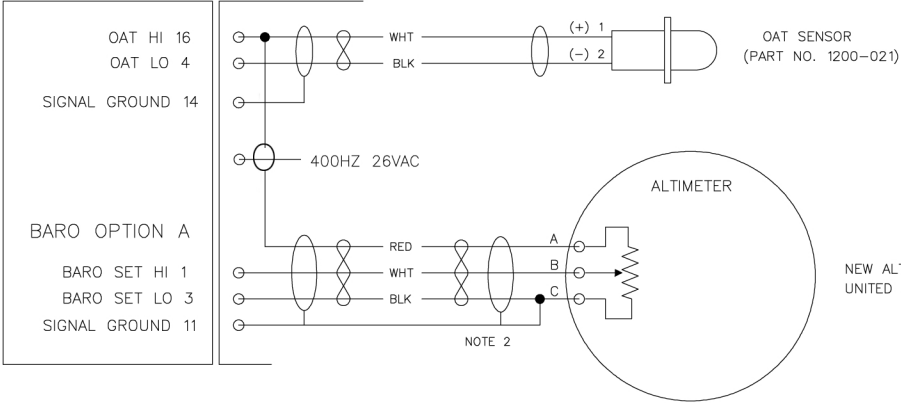

NEW ALTIMETER INSTALLATION  
UNITED ALTIMETER

TAS 1000 DISPLAY  
(P/N 1000-001)  
(DSUB-25 SOCKET)

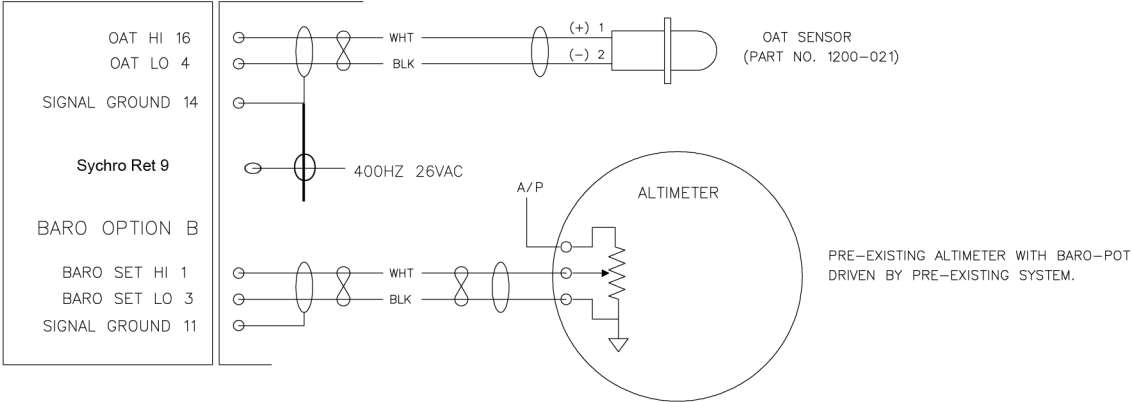

PRE-EXISTING ALTIMETER WITH BARO-POT  
DRIVEN BY PRE-EXISTING SYSTEM.

TAS 1000 DISPLAY  
(P/N 1000-001)  
(DSUB-25 SOCKET)

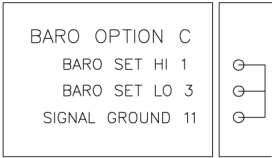

1. WIRING FOR TAS1000 MOD "D".
2. PIN "C" ON ALTIMETER MUST BE CONNECTED TO SHIELD GROUND.

<b>Insight</b>		TAS 1000 INSTALLATION SCHEMATIC					
		Insight Instrument Corporation Box 122, Fort Erie, Ontario L2A 5M6					
SIZE	FILE NAME:	DRAWING NO.	DRN	CKD	QCD	REV	
	tasin2j	1000-301	But	But	But	J	
SCALE	DATE	SHEET	2 of 4				
none	SEPT 1/99						

This drawing is the property of Insight Instrument Corporation and contains confidential and proprietary information. Reproduction or unauthorized use is strictly forbidden.  
© Copyright 1999